

Still R60-20

Electric Forklift • Electrostivuitoar

Load capacity	2000 kg
Lift height	4 meters
Tire type	L/V 4 (Superelastic/pneumatic)
Center of gravity	500 mm
Drive system	Electric motor 80 V
Traction motor	12.5 kW
Hoist motor	13.5 kW
Total weight	3967 kg
Battery weight	1558 kg
Overall dimensions	Total length 3262 mm, width 1192 mm
Maximum speed	16 km/h
Braking system	Electric/hydraulic brakes
Outer turning radius	1954 mm
Maximum gradeability loaded/unloaded	20% / 24%

Disclaimer • Information according to the manufacturer. Data and information without guarantee. Subject to errors and changes. Kran Liability excluded. • Date în conformitate cu producătorul.
Date și informații fără garanție, supuse erorilor și modificărilor. Răspunderea Kran este exclusă.

Still R60-20

Electric Forklift • Electrostivuitoar

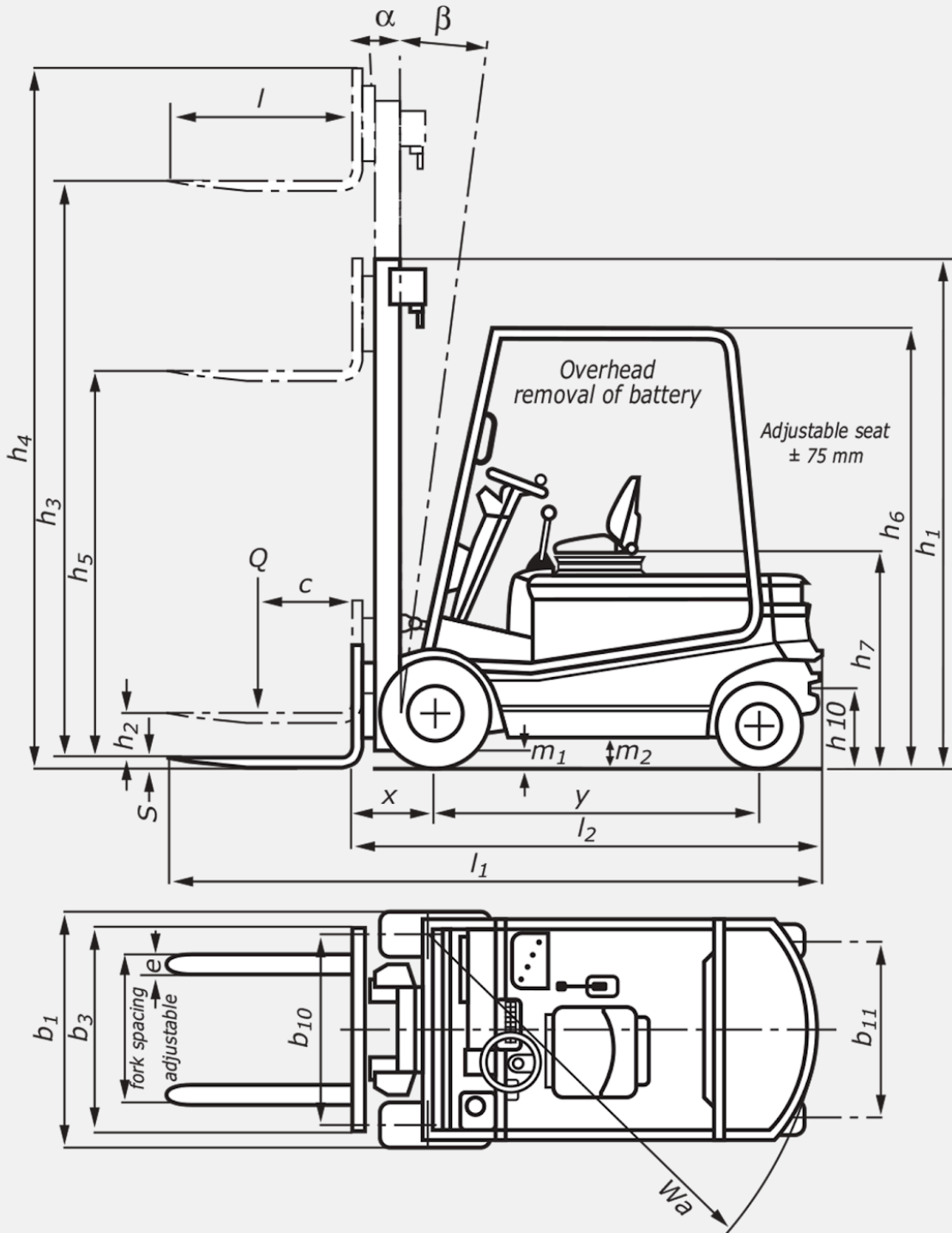

Disclaimer • Information according to the manufacturer. Data and information without guarantee. Subject to errors and changes. Kran Liability excluded. • Date în conformitate cu producătorul.
Date și informații fără garanție, supuse erorilor și modificărilor. Răspunderea Kran este exclusă.

Still R60-20

Electric Forklift • Electrostivuito

Attribute	Unit	Value
Type of control - hand, pedestrian, stand-on, rider seated		rider seated
Carrying capacity/load	Q (kg)	2200
Load centre	c (mm)	500
Load distance	x (mm)	415
Wheelbase	y (mm)	1535
Weight	kg	4149
Axle loadings laden front	kg	5687
Axle loadings laden rear	kg	662
Axle loadings unladen front	kg	2176
Axle loadings unladen rear	kg	1973
Tyres - rubber (V), superelastic (SE), pneumatic (L), polyurethane (PE)	SE/L	V
Tyre size - front		23x9-10 (20 PR) / 21x9x13
Tyre size - rear		18x7-8 (14 PR) / 16x6x10.5
Wheels - number front (x = drive wheel)		2x
Wheels - number rear (x = drive wheel)		2
Track width - front	b10 (mm)	945 / 961
Track width - rear	b11 (mm)	900 / 880
Tilt angle, mast/fork carriage forwards	degrees	3
Tilt angle, mast/fork carriage backwards	degrees	10
Closed height	h1 (mm)	2250 / 2230
Free lift	h2 (mm)	160
Lift height	h3 (mm)	3220
Height, mast raised	h4 (mm)	3880
Height to top of overhead guard (cabin)	h6 (mm)	2250 / 2230
Seat height	h7 (mm)	1070 / 1050
Coupling height	h10 (mm)	392 / 372
Overall length	l1 (mm)	3262
Length to front face of forks	l2 (mm)	2262
Overall width	b1 (mm)	1192 / 1199
Fork thickness	s (mm)	40
Fork width	e (mm)	100
Fork length	l (mm)	1000
Fork carriage to DIN 15173 - class / form A or B		ISO II B
Fork carriage width	b3 (mm)	1040
Ground clearance beneath mast, laden	m1 (mm)	100 / 80
Ground clearance at centre of wheelbase	m2 (mm)	138 / 120
Aisle width for pallets 1000 x 1200 wide	Ast (mm)	3569
Aisle width for pallets 800 x 1200 long	Ast (mm)	3769
Outer turning radius	Wa (mm)	1954
Speed laden	km/h	16
Speed unladen	km/h	16
Lift speed laden	m/s	0.4
Lift speed unladen	m/s	0.52
Lowering speed laden	m/s	0.6

Still R60-20

Electric Forklift • Electrostrivuito

Attribute	Unit	Value
Lowering speed unladen	m/s	0.45
Rated drawbar pull laden	N	3900
Rated drawbar pull unladen	N	4300
Max. drawbar pull laden	N	10780
Max. drawbar pull unladen	N	11190
Gradeability laden	%	8
Gradeability unladen	%	13
Max. gradeability laden	%	20
Max. gradeability unladen	%	24
Acceleration time laden	s	5
Acceleration time unladen	s	4.6
Brakes		electr./hydr.
Drive motor hourly capacity	kW	12.5
Hoist motor capacity at 15% duty factor	kW	13.5
Battery equipment to DIN 43531/35/36 A, B, C, no		43536 A
Battery voltage	U (V)	80
Battery capacity	K 5 (Ah)	560L [400-620]
Battery weight	kg	1558
Drive control		Stilltronic-SCR
Operating pressure for attachments	bar	170
Trailer coupling, type/DIN		pin

Disclaimer • Information according to the manufacturer. Data and information without guarantee. Subject to errors and changes. Kran Liability excluded. • Date în conformitate cu producătorul.
 Date și informații fără garanție, supuse erorilor și modificărilor. Răspunderea Kran este exclusă.