

Hyster H7.00 L GPL

LPG Forklift • Stivuitoar GPL

Load capacity	7,000 kg
Lifting height	5,340 mm
Load center	600 mm
Engine	GM V6-4.3L LPG
Engine power	65.2 kW
Weight	8,700 kg
Tire dimensions (front/rear)	8.25 x 15 12PR
Travel speed (loaded/unloaded)	23.7 / 24.0 km/h
Fork dimensions	60 x 150 x 1,200 mm
Mast tilt angle (forward/backward)	5° / 10°
Overall length	5,390 mm
Overall width	2,110 mm
Overhead guard height	2,310 mm

Disclaimer • Information according to the manufacturer. Data and information without guarantee, subject to errors and changes. Kran Liability excluded. • Date în conformitate cu producătorul. Date și informații fără garanție, supuse erorilor și modificărilor. Răspunderea Kran este exclusă.

Hyster H7.00 L GPL
LPG Forklift • Stivuito GPL

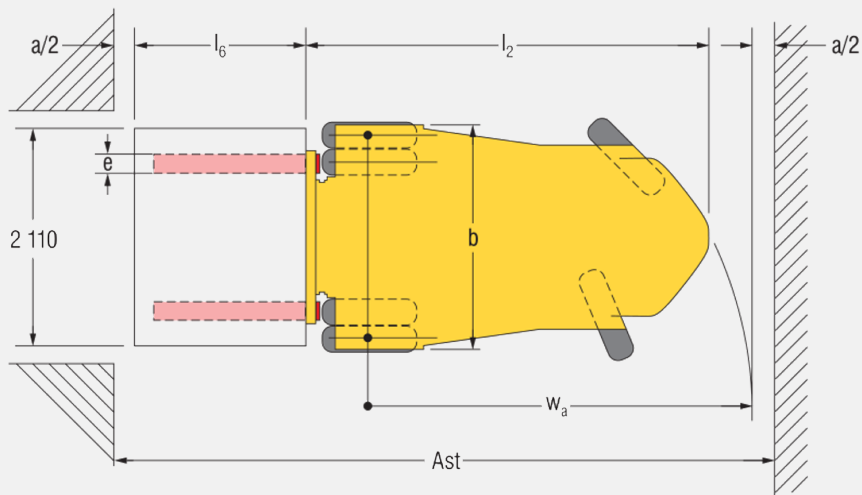
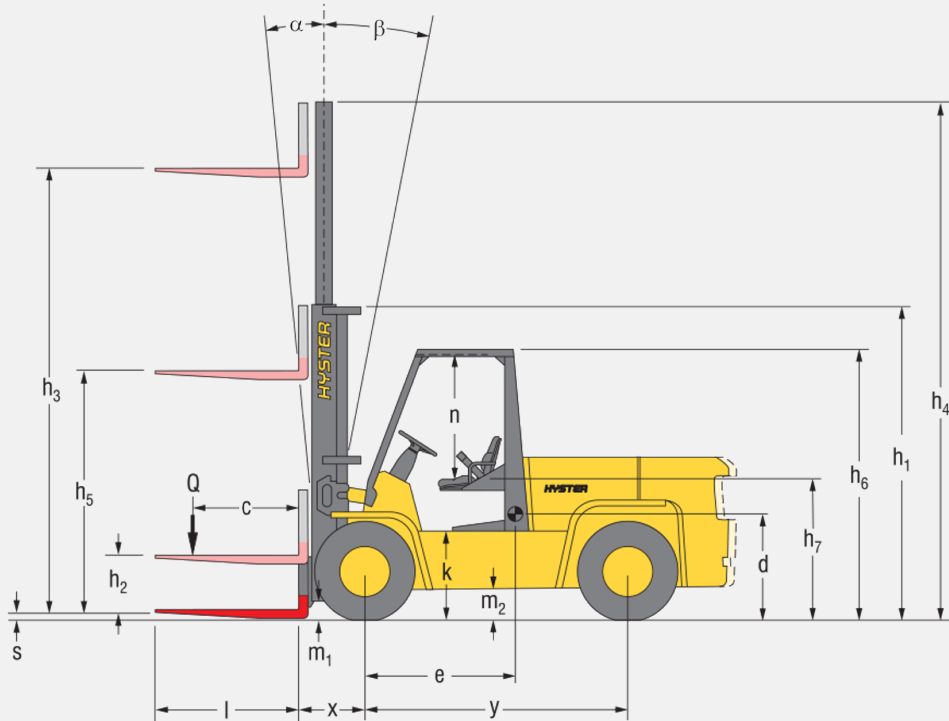

= Centre of gravity of unladen truck

$Ast = Wa + x + l6 + a$ (see lines 4.33 & 4.34)

a = Minimum operating clearance

(VDI standard = 200 mm BITA recommendation = 300 mm)

$l6$ = Load length

Disclaimer • Information according to the manufacturer. Data and Information without guarantee, subject to errors and changes. Kran Liability excluded. • Date în conformitate cu producătorul. Date și informații fără garanție, supuse erorilor și modificărilor. Răspunderea Kran este exclusă.

Hyster H7.00 L GPL

LPG Forklift • Stivuito GPL

Load capacity	Q (kg)	7 000
Load centre	c (mm)	600
Load distance	x (mm)	580
Wheelbase	y (mm)	2 240
Unladen weight	kg	8 700
Axle loading with load, front/rear	kg	14 170 / 1 530
Axle loading without load, front/rear	kg	3 470 / 5 230
Tyres: L = pneumatic, V = solid, SE = pneumatic-shaped solid		L
Tyre size, front		8.25 x 15 12PR
Tyre size, rear		8.25 x 15 12PR
Number of wheels, front/rear (X = driven)		4X / 3
Track width, front	b10 (mm)	1 850
Track width, rear	b11 (mm)	1 540
Mast tilt, α = forward/ β = back	degrees	5 / 10
Height of mast, lowered	h1 (mm)	3 740
Free lift	h2 (mm)	100
Lift height	h3 (mm)	5 340
Height of mast, extended with/without load backrest extension	h4 (mm)	6 950 / 6 610
Overhead guard height	h5 (mm)	2 310
Seat height	h7 (mm)	1 190
Overall length	l1 (mm)	5 390
Length to face of forks	l2 (mm)	2 110
Overall width	b1 (mm)	2 110
Fork dimensions	s/e/l (mm)	60 / 150 / 1 200
Ground clearance under mast, with load	m1 (mm)	156
Ground clearance, centre of wheelbase	m2 (mm)	253
Aisle width with pallets 1000 mm x 1200 mm wide	Ast (mm)	4 970
Aisle width with pallets 800 mm x 1200 mm long	Ast (mm)	5 170
Outer turning radius	Wa (mm)	3 390
Travel speed with/without load	km/h	23.7 / 24.0
Lifting speed with/without load	m/sec	0.41 / 0.44
Lowering speed with/without load	m/sec	0.58 / 0.53
Drawbar pull with/without load	N	342 / 257
Gradeability with/without load	%	23 / 24
Service brake		Hydraulic
Engine manufacturer/type		GM / V6-4.3L
Engine output in accordance with ISO 1585	kW	65.2
Governed speed	rpm	2 500
Number of cylinders/displacements	cm ³	6 / 4 300
Fuel consumption in accordance with VDI cycle	l/h	10.9
Drive control		Torque Converter
Working pressure for attachments	bar	155
Average noise level at operator's ear (Lpaz), without cab	dB (A)	85
Guaranteed sound power (Lwaz)	dB	112
Towing coupling type		Pin

Disclaimer • Information according to the manufacturer. Data and information without guarantee, subject to errors and changes. Kran Liability excluded. • Date în conformitate cu producătorul. Date și informații fără garanție, supuse erorilor și modificărilor. Răspunderea Kran este exclusă.

Kran Constanța

+40 757 016 913

contact@kran.ro